

## AT 150/4/340 C. 285-290-295

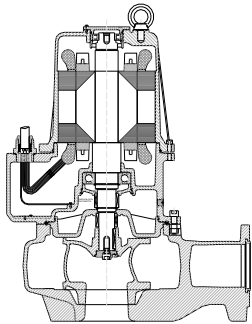

Su richiesta  
On request  
Sur requête



GIRANTE MONOCANALE  
IMPELLER SINGLECHANNEL  
ROUE MONOCANAL

PASSAGGIO LIBERO  
FREE PASSAGE  
SECTION DE PASSAGE

C. 285	110mm
C. 290	120mm
C. 295	130mm

ALBERO MOTORE	AISI 420
MOTOR SHAFT	AISI 420
ARBRE MOTEUR	AISI 420

Curve secondo ISO 9906. Livello 2  
Curves as per ISO 9906. Grade 2  
Courbes selon ISO 9906. Niveau 2

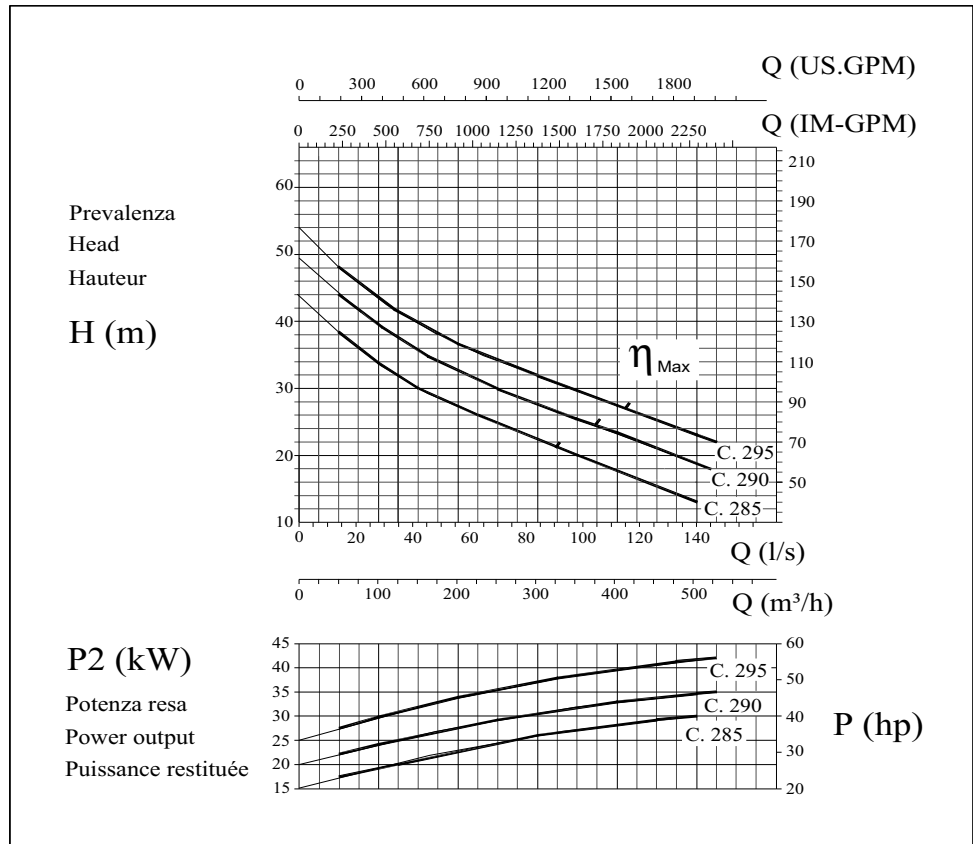

Elettropompa Tipo Electric pump Type Electropompe Type	Prevalenza - Head - Hauteur										
	10	14	18	22	26	30	34	38	42	46	48
	1	1,4	1,8	2,2	2,6	3	3,4	3,8	4,2	4,6	4,8
		Portata - Capacity - Débit									
		Q (l/s)									
AT 150/4/340 C. 285		130	107	85	62	42	25,5	15			
AT 150/4/340 C. 290			145	119	92,5	67	48	33	20		
AT 150/4/340 C. 295				147	120	96	70	48	33	19	14

Dati tecnici / Specifications / Données

	Mandata Delivery Refoulement	kW		r.p.m	Poles	Ampere	Hz	Cos
		P1	P2	1/min		Trifase 3~		
						400V		
AT 150/4/340 C. 285	DN2 150	39,8	29,5	1450	4	56	50	0,82
AT 150/4/340 C. 290		46,7	35	1450	4	68	50	0,82
AT 150/4/340 C. 295		58	43	1450	4	81	50	0,82

Dimensioni di ingombro  
Overall dimensions of packing  
Dimensions d'encombrement des emballages

TIPO-TYPE	X	Y	Z	Kg
AT 150/4/340 C. 285	604	1038	800	550
AT 150/4/340 C. 290	604	1038	800	585
AT 150/4/340 C. 295	604	1038	800	590

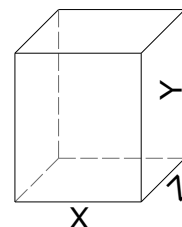

## AT 150/4/340 C.285-290-295



INSTALLAZIONE FISSA  
STATIONARY INSTALLATION  
INSTALLATION FIXE

INSTALLAZIONE MOBILE  
MOBILE INSTALLATION  
INSTALLATION PORTABLE

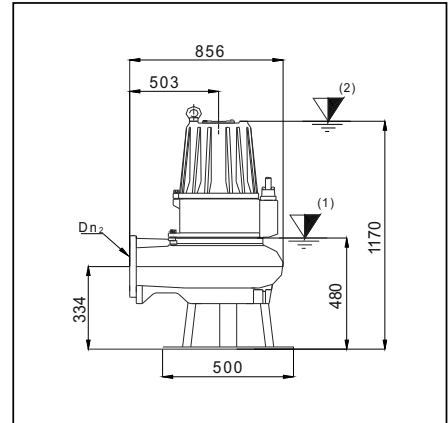
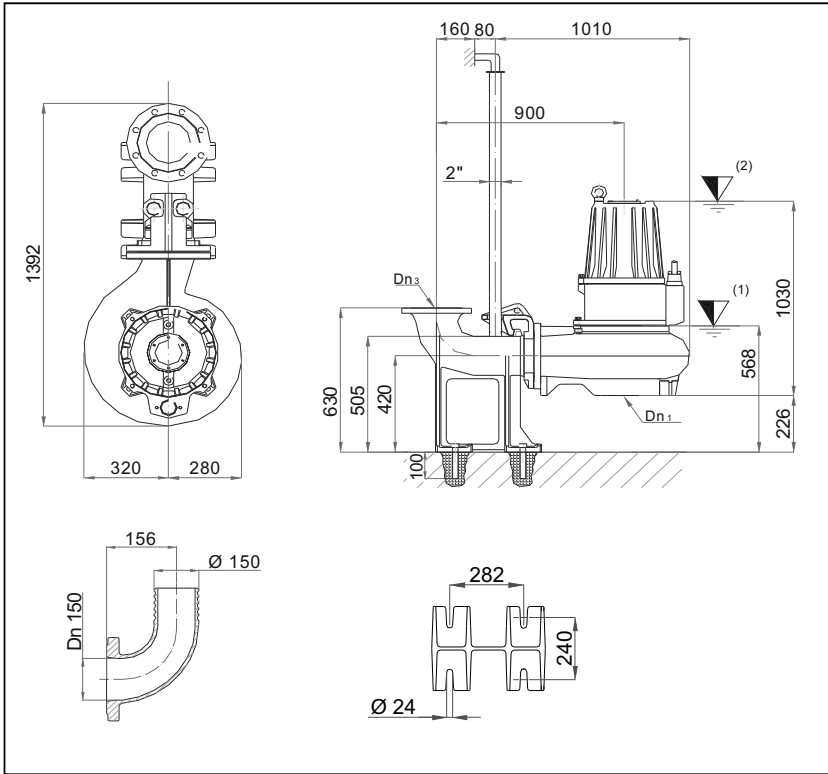

Dimensioni flange UNI  
UNI flange dimensions  
Dimensions brides UNI

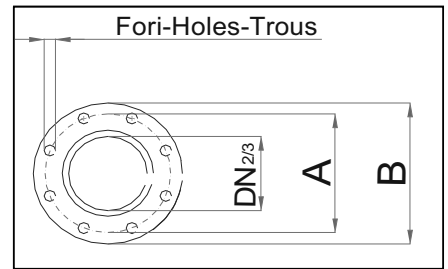

DIMENSIONI FLANGE UNI - UNI FLANGE DIMENSIONS - DIMENSIONS BRIDES UNI

TIPO - TYPE	DN <sub>1</sub>	DN <sub>2/3</sub>	A	B	Fori - Holes - Trous		OPTIONAL			
					n°	mm				
AT 150/4/340 C.285 AT 150/4/340 C.290 AT 150/4/340 C.295	150	150	240	285	8	22	P8-DN 150	B8-DN 150	DN 150 - PN 16	

CARATTERISTICHE TECNICHE - TECHNICAL FEATURES - CARACTERISTIQUES TECHNIQUES

TIPO - TYPE	CAVO - CABLE H07 - RNF	MT	Sonde termiche	si				
			Thermal probes	yes				
AT 150/4/340 C.285 AT 150/4/340 C.290 AT 150/4/340 C.295	(1) 7x10+5x1 Ø 29 Y-Δ	10	Sondes thermiques	oui	Superiore Upper Supérieur	Inferiore Lower Inférieur	Superiore Upper Supérieur	Inferiore Lower Inférieur
			Sonda di conduttività	si				
			Conductivity probe	yes				
			Sonde de conductivité	oui				

NOTE - NOTES - NOTES :



Punto inferiore d'arresto nel caso di funzionamento automatico  
Lowest shut-off point for automatic operation  
Point d'arrêt le plus bas en service automatique

DRENO POMPE si riserva di modificare senza preavviso i dati riportati in questo catalogo

DRENO POMPE can alter without notifications the data mentioned in this catalogue



Sommergenza minima nel caso di funzionamento continuo  
Minimum covering for continuous operation  
Recouvrement minimal pour service continu

DRENO POMPE se réserve le droit de modifier sans préavis les données techniques dans ce catalogue