

HT 65/2/152 C. 502-503

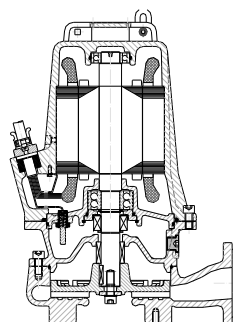

Su richiesta
On request
Sur requête



GIRANTE QUADRICANALE
IMPELLER FOUR-CHANNEL
ROUE QUADRI CANAL

PASSAGGIO LIBERO	10mm
FREE PASSAGE	10mm
SECTION DE PASSAGE	10mm

ALBERO MOTORE	AISI 420
MOTOR SHAFT	AISI 420
ARBRE MOTEUR	AISI 420

Curve secondo ISO 9906. Livello 2
Curves as per ISO 9906. Grade 2
Courbes selon ISO 9906. Niveau 2

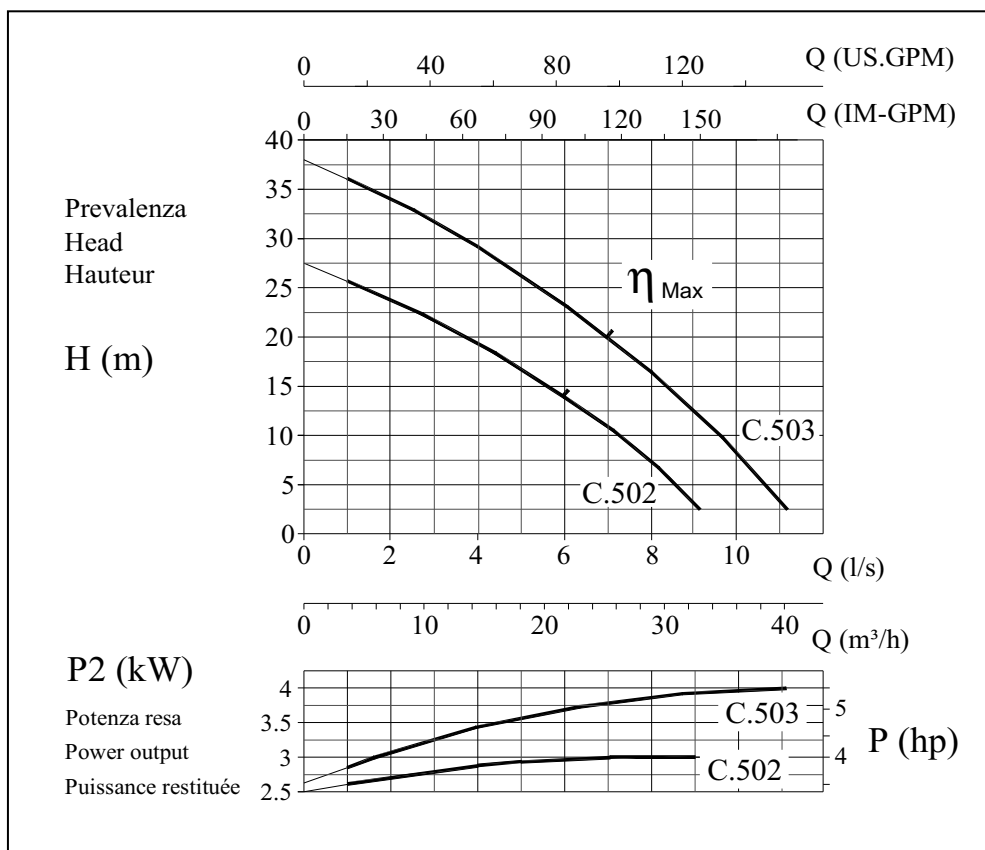

Elettropompa Tipo Electric pump Type Electropompe Type	Prevalenza - Head - Hauteur										
	$\frac{Hm}{bar}$										
	1	2,5	5	10	15	20	25	30	35	38	40
	0,1	0,25	0,5	1	1,5	2	2,5	3	3,5	3,8	4
Portata - Capacity - Débit											
	Q (l/s)										
HT 65/2/152 C. 502		9	8,5	7,2	5,6	4	1,5				
HT 65/2/152 C. 503		10,5	9,6	9,6	8,3	7	5,2	3,6	1,5		

Dati tecnici / Specifications / Données

	Mandata Delivery Refoulement	kW		r.p.m	Poles	Ampere Trifase 3~ 400V	Hz	Cos	
		P1	P2	1/min					
HT 65/2/152 C. 502	DN2 65	4,6	3	2850	2	7,5	50	0,89	
HT 65/2/152 C. 503		5,1	4	2850	2	8,2	50	0,91	

Dimensioni di ingombro

Overall dimensions of packing

Dimensions d'encombrement des emballages

TIPO-TYPE	X	Y	Z	Kg
HT 65/2/152 C. 502	285	540	370	61
HT 65/2/152 C. 503	285	540	370	63

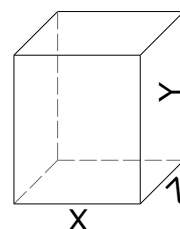

HT 65/2/152 C.502-503



INSTALLAZIONE FISSA
STATIONARY INSTALLATION
INSTALLATION FIXE

INSTALLAZIONE MOBILE
MOBILE INSTALLATION
INSTALLATION PORTABLE

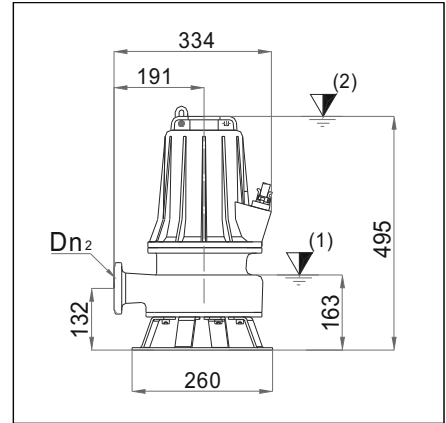
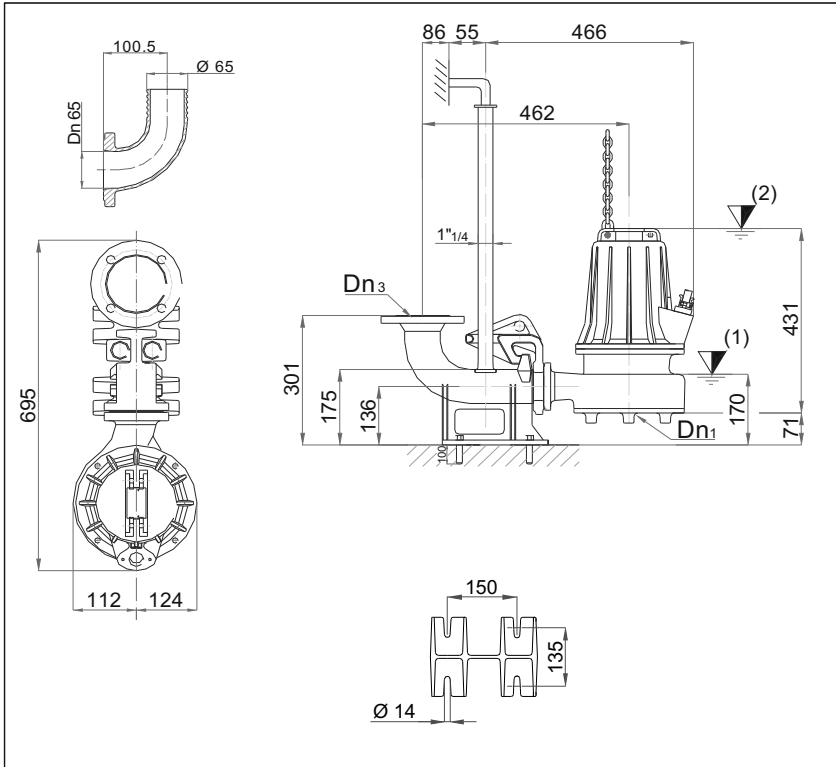

Dimensioni flange UNI
UNI flange dimensions
Dimensions brides UNI

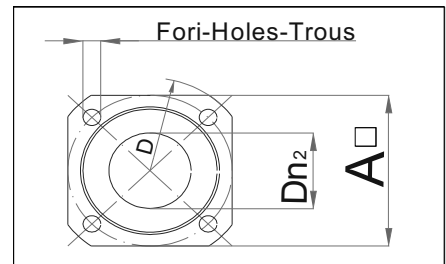

DIMENSIONI FLANGE UNI - UNI FLANGE DIMENSIONS - DIMENSIONS BRIDES UNI

TIPO - TYPE	DN ₁	DN _{2/3}	A	B	Fori - Holes - Trous		OPTIONAL			
					n°	mm				
HT 65/2/152 C.502 HT 65/2/152 C.503	65	65	130	160	4	14				
							P4-DN 65	B4-DN 65	DN 65	

CARATTERISTICHE TECNICHE - TECHNICAL FEATURES - CARACTERISTIQUES TECHNIQUES

TIPO - TYPE	CAVO - CABLE H07 - RNF	MT	Sonde termiche		OPTIONAL			
			si	yes				
HT 65/2/152 C.502 HT 65/2/152 C.503	(1) 7x1,5 φ 15 AVV. DIRETTO	10	Sondes thermiques	oui	Superiore Upper Supérieur	Inferiore Lower Inférieur	Superiore Upper Supérieur	Inferiore Lower Inférieur
			Sonda di conduttività	si				
			Conductivity probe	yes				
			Sonde de conductivité	oui	AR 25	MG1/25G/G5	6205 2Z	3205 2Z

NOTE - NOTES - NOTES :



Punto inferiore d'arresto nel caso di funzionamento automatico
Lowest shut-off point for automatic operation
Point d'arrêt le plus bas en service automatique

DRENO POMPE si riserva di modificare senza preavviso i dati riportati in questo catalogo

DRENO POMPE can alter without notifications the data mentioned in this catalogue



Sommergenza minima nel caso di funzionamento continuo
Minimum covering for continuous operation
Recouvrement minimal pour service continu

DRENO POMPE se réserve le droit de modifier sans préavis les données techniques dans ce catalogue