

# NOVABOX

## AUTOMATIC STATIONS FOR COLLECTING AND LIFTING WASTE WATER



Automatic stations for collecting and lifting domestic waste water from bath tubs, wash basins, showers and washing machines located in basements or below the level of the sewage network.

Equipped with a NOVA 300 electropump with 5 metres of power cable and plug mounted on a technopolymer plate, a 30-litre container in technopolymer and a check valve on delivery.

Supplied with pump already assembled, ready to use

**Operating range:** from 1 to 7.5 m<sup>3</sup>/h with head up to 6.9 metres

**Liquid temperature range:** +50°C  
+90°C for a max. time of 3 min.

**Pumped liquid:** waste water free from solids and/or fibres

**Pump motor protection level:** IP 68

**Motor insulation class:** F

### ELECTRICAL AND HYDRAULIC DATA

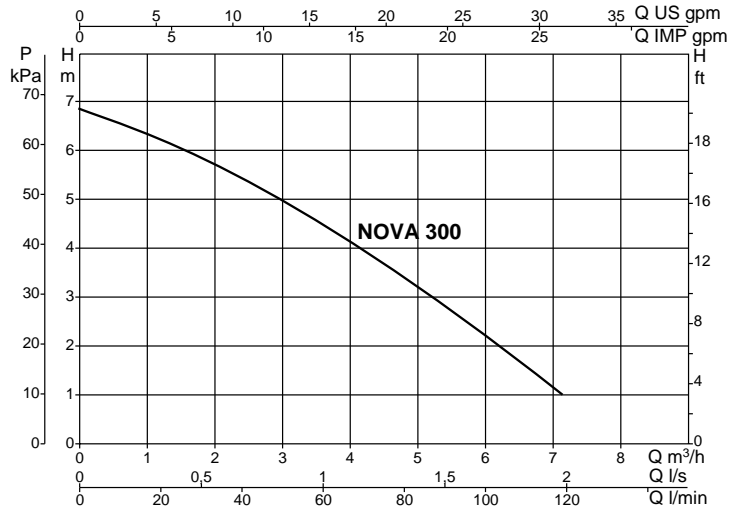

MODEL	ELECTRICAL DATA						HYDRAULIC DATA											
	VOLTAGE 50 Hz	P1 MAX kW	P2 NOMINAL kW HP		In A	CAPACITOR μF Vc	Q m <sup>3</sup> /h l/min	0	2,4 40	4,8 80	6 100	7,2 120	H (m)	6,9	5,3	3,2	2	1
<b>NOVABOX 30/300.1</b>	1x220-240 V ~	0,35	0,22	0,3	1,5	8 450												

### DIMENSIONS AND WEIGHTS

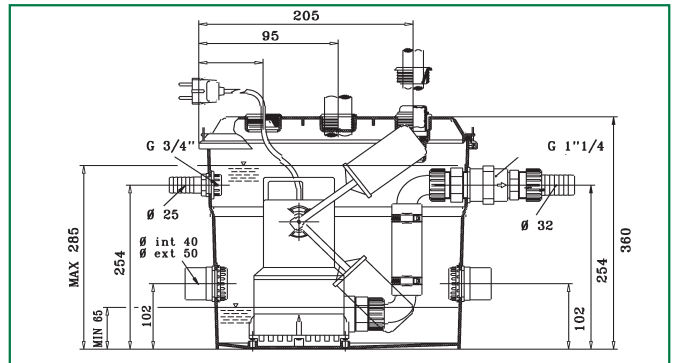
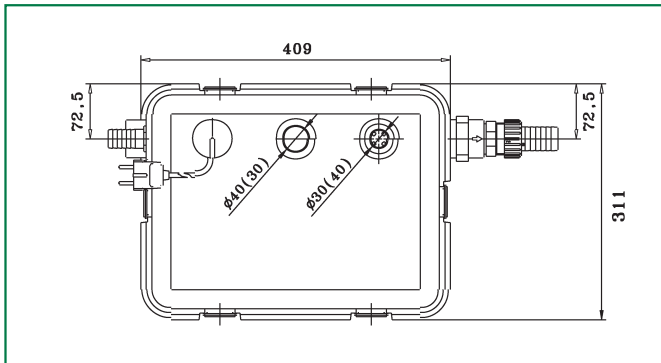

MODEL	A	B	C	D	E	F	H	H1	H2	PACKING DIMENSIONS			VOLUME m <sup>3</sup>	WEIGHT Kg
										L/A	L/B	H		
<b>NOVABOX 30/300.1</b>	407	309	94	204	314	72	360	100	254	45	33	38	0,056	9,2